

PART NO.	"A" REF.	"B" REF.	"C" REF.	"D" HOLDING DIA.	"E" REF.	"F" REF.	"G" ±.020 [0.5]	"H" REF.	"I" [REF.]	"L" ±.030 [0.8]	WALL REF.		
V- 1000	.30 [7.5]	.19 [4.8]	.50 [12.7]	.25 [6.4]	.04 [1.0]	.094 [2.4]	.250 [6.4]	SINGLE HOLE IN CENTER	.135 [3.4]	.50 [12.7]	.040 [1.0]		
V- 1001	.36 [9.1]			.31 [7.9]	.06 [1.5]				.140 [3.6]		.045 [1.1]		
V- 1002	.41 [10.3]			.38 [9.5]									
V- 1003	.45 [11.5]	.52 [13.1]	.44 [11.1]										
V- 1004	.50 [12.7]	.22 [5.6]	.66 [16.7]	.50 [12.7]	.04 [1.0]	.156 [4.0]	.190 [4.8]	.75 [19.1]	.160 [4.1]	.050 [1.3]	.060 [1.5]		
V- 1005	.61 [15.5]			.72 [18.3]								.56 [14.3]	
V- 1006	.63 [15.9]	.34 [8.6]	.84 [21.0]	.63 [15.9]	.06 [1.5]	.156 [4.0]	.500 [12.7]	.75 [19.1]	.185 [4.7]	1.13 [28.5]	.065 [1.7]		
V- 1007	.63 [15.9]			.34 [8.6]					.84 [21.0]			.69 [17.6]	.235 [6.0]
V- 1008	.78 [19.8]			.36 [9.1]					.89 [22.6]			.75 [19.1]	.245 [6.2]
V- 1009	.91 [23.0]	.41 [10.4]	1.08 [27.4]	.88 [22.2]	.19 [4.8]	.156 [4.0]	.375 [9.5]	.75 [19.1]	.235 [6.0]	1.75 [44.5]	.075 [1.9]		
V- 1010	.98 [25.0]			1.13 [28.6]					1.00 [25.4]			.12 [3.0]	.280 [7.1]
V- 1011	1.34 [34.1]	.44 [11.2]	1.25 [31.8]	1.38 [34.9]	.22 [5.6]	.156 [4.0]	.500 [12.7]	.75 [19.1]	.295 [7.5]	1.50 [38.1]	.093 [2.4]		
V- 1024	1.81 [46.0]			1.42 [36.1]					1.50 [38.1]				
V- 1028	1.92 [48.8]			1.50 [38.1]					1.75 [44.5]				
V- 1030	2.44 [61.9]	.52 [13.2]	2.61 [66.3]	2.25-2.75 [57.1-69.9]					.343 [8.7]				

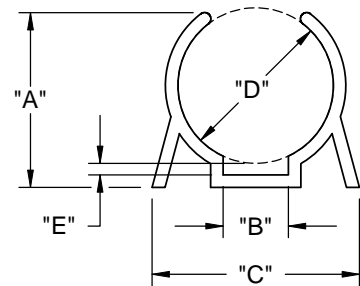

THIS STYLE ON
V-1000 THRU V-1009

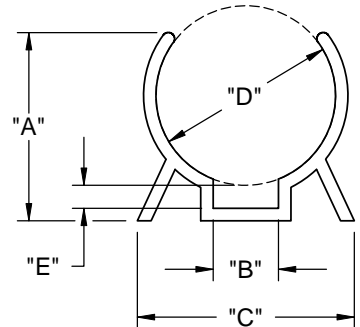

THIS STYLE ON
V-1010 & V-1011

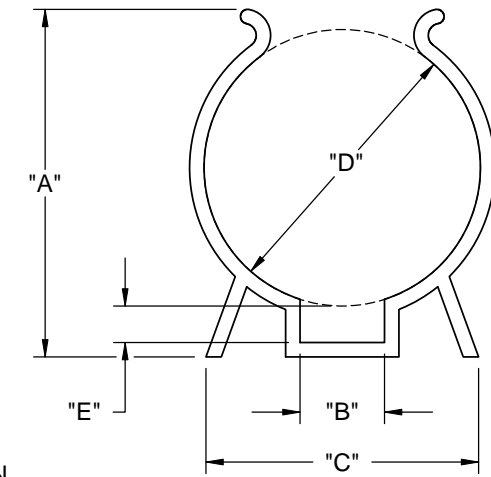

THIS STYLE ON
V-1024, V-1028, & V-1030

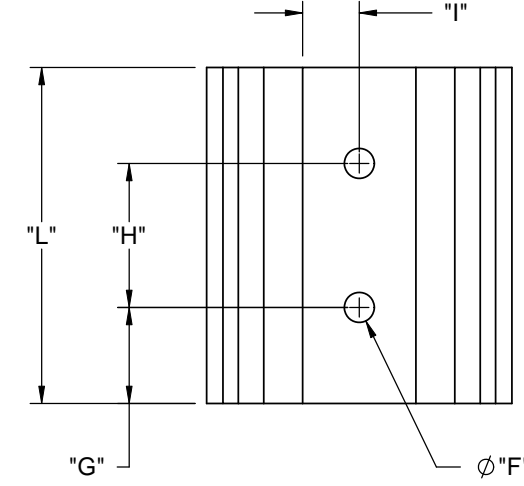
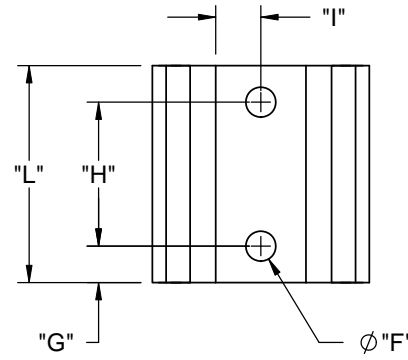
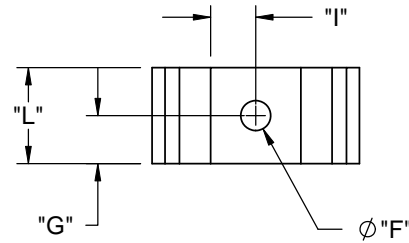

- NOTES:
1. MATERIAL: PVC (RMS-4)
2. COLOR: BLACK
3. DIMENSION "E" APPLIES TO PART WITH NOMINAL DIA. ROD IN PLACE.
4. CUSTOM LENGTHS AVAILABLE BY SPECIAL ORDER.

K	SEE CO # 200258 FOR CHANGES	SK	10/09/08
J	SEE CO # 200211 FOR CHANGES	SK	07/07/08
-	SEE ENGINEERING FOR REV A-I	-	-
REV.	DESCRIPTION	ENGR.	DATE

TITLE: COMPONENT CLIPS				DWG IN IN [MM]		FINAL	
CREATED USING SOLIDWORKS	FILE #: V-CLIPS	DWN: R.D.G.	APP: R.D.G.	PART #			
TOLERANCES UNLESS NOTED .XX=±.02 .XXX=±.015 FRAC.=±1/32 ANG.=±3°	SHEET: 1 OF 1 SHEET SIZE: B	DT: 06/23/08	CHKD: D.Z.	SEE TABLE		PRINT TYPE	
RE: RICHCO, INC.	RICHCO, INC. ENG@RICHCO-INC.COM (773) 539-4060				CA		